

DELINA STONE VILLA

STONE VILLA | PLAKA | APOKORONAS AREA | WEST CRETE



KYRIAKIDIS
PRESENTATION



STONE VILLA | PLAKA | APOKORONAS AREA | WEST CRETE

DELINA STONE VILLA

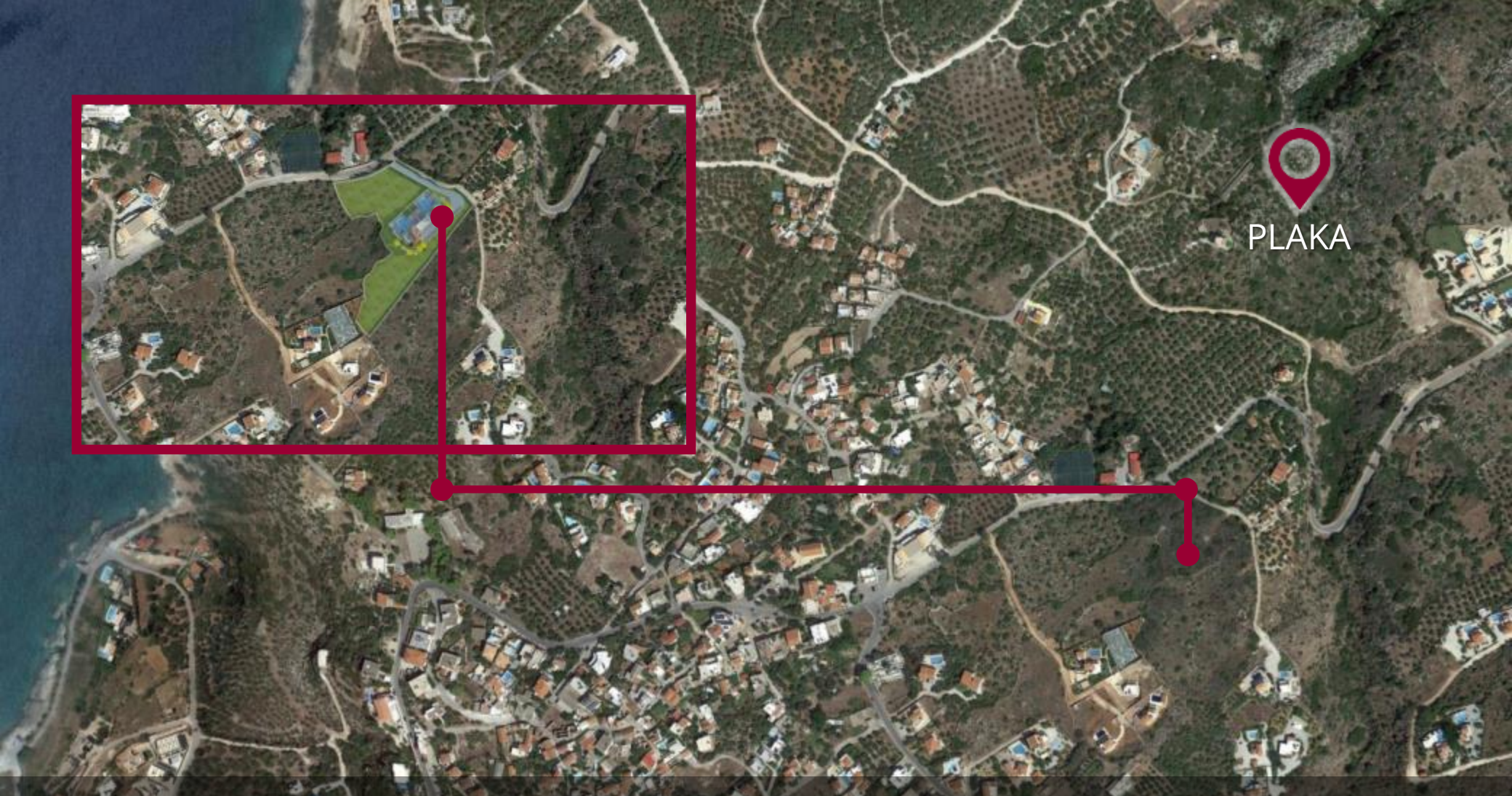



PLAKA

DELINA STONE VILLA

STONE VILLA | PLAKA | APOKORONAS AREA | WEST CRETE



DISTANCES





Plaka Village in **Chania** Crete is one of the most known **traditional villages** in **West Crete**, in Apokoronas area. It is located 23 km. from Chania and belongs to Vamos Municipality along with the neighboring villages Almyrida and Kalyves. Unlike these villages, Plaka is not on the coast, but on a small hill (70 meters). Plaka village built amphitheatrically; offering excellent views of Almyrida and of course the blue Cretan Sea and Souda Bay. The village is verdant and largely retains its beautiful natural environment, as it is located on the slope of the Mountain *Drapanokefalas* where the vegetation is intense and varied. You can see olives and planes, undergrowth of shrubs, but also organically grown plants that have not altered the character of the area. Plaka has about 400 permanent residents, half of whom are foreigners, mainly British.

The village retains its traditional character to a large extent, although the locals will tell you that due to the recent construction, it has started losing its individuality

The village has a beautiful main square which is attractive to all visitors, since it is the meeting point for locals and foreign, in the traditional cafes or taverns of the square. The inhabitants of Plaka deal with their farms, and the production of olive oil, wine and raki in the region is widespread. In the local shops and taverns you will find local wine of high quality, not only to drink during your stay there, but also to take with you. The nearest beach is in Almyrida, about 1 km from Plaka, other beaches that can be found in the area are the beaches of Kalyves and the beach in Georgioupolis.





DELINA STONE VILLA

Description | Photos

About villa

Delina is a modern and fully equipped new villa near the traditional village of Plaka in western Crete (Chania region) with stunning views of the sea and the White Mountains.

Land plot

The villa is located on a plot of **3,800 m²**. A young olive garden of 40 trees is planted on 1,200 m² in front of the house and next to it. There are also 2 lawns with thick grass, where you can spend time with your family (have picnics, play frisbee, badminton, etc.). The area around the villa is decorated with rose bushes and palm trees. All plants are automatically watered.

Behind the villa, there is the second part of the land plot belonging to it with an area of **1,500 m²**. This plot is ideal for building a tennis court. It also has significant prospects. At the moment, the expansion of the boundaries of the village of Plaka is being considered. When the boundaries of the village are expanded, this site can be separated and, according to the law, it will be allowed to build villa(s) there. Thus, the new owner will either be able to build several properties themselves or be able to sell the site at a very favorable price.

A beautiful stone fence was erected around the perimeter of the entire land plot.

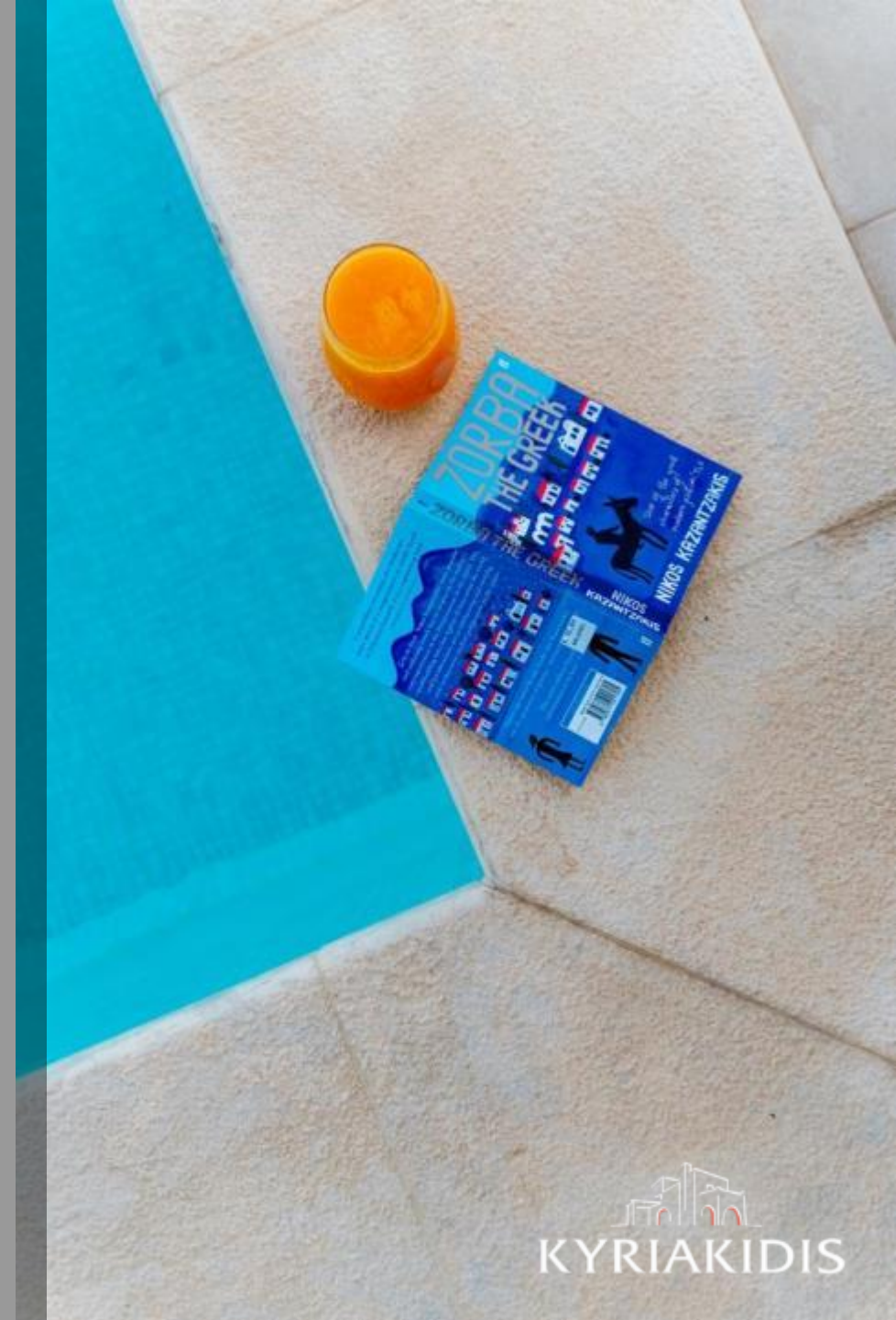



Neighbours

Villa Delina is located in a quiet place and has only one neighbor - the exact twin villa. Neighbors are intelligent and kind people who occasionally go there as to a country house. The neighboring villa is not rented out, which will provide privacy and silence to the owners of Delina.

The twin villas are connected to each other, but at the same time, they are completely separate.



Renovation and interior

Villa Delina is being sold with a new high-quality renovation, fully furnished, equipped with household appliances and decor. The house is furnished with expensive European-made interior items of the highest quality. Cabinets and kitchen are made to order. There is a beautiful fireplace in the hall of the villa.

When designing villa Delina, an unusual and beautiful architectural solution was used - the first floor has a mezzanine-type layout. It is divided into 2 flights: a flight of stairs and a flight in the center. Thus, the ground floor, namely the dining area, is visible from the first floor.



Pool and barbecue area

The swimming pool with an area of 52.50 m² has a comfortable depth and overlooks the sea and the mountains. In the evening, the pool lighting looks beautiful. A modern water purification system has been installed. There is also an outdoor shower near the pool. Lighting has also been installed throughout the yard.

There is beautiful and high-quality garden furniture in the pool and barbecue areas; umbrellas are installed.

Garage

A garage with automatic gates and glazed windows adjoins the house, which allows storing garden upholstered furniture in the garage in winter.

WiFi

Throughout the villa, including the pool and barbecue area, a stable and high-quality Wi-Fi signal is provided.



DETAILS

Project name  **DELINA VILLA**

Location  **Crete | Plaka**

Plot size  **3.800 m²**

Total property size  **203 m²**

Levels  **2**

Ground floor size  **201,5 m²**

First floor size  **201,5 m²**

Bedrooms  **3**

Bathrooms  **3**

Pool size  **52 m²**

Heating  **Diesel heating**

Air condition  **In each room**

Price  **950.000**





BEDROOM 1





 **BEDROOM 2**





 **BEDROOM 3**









DELINA STONE VILLA

PLANS

Delina Stone Villa

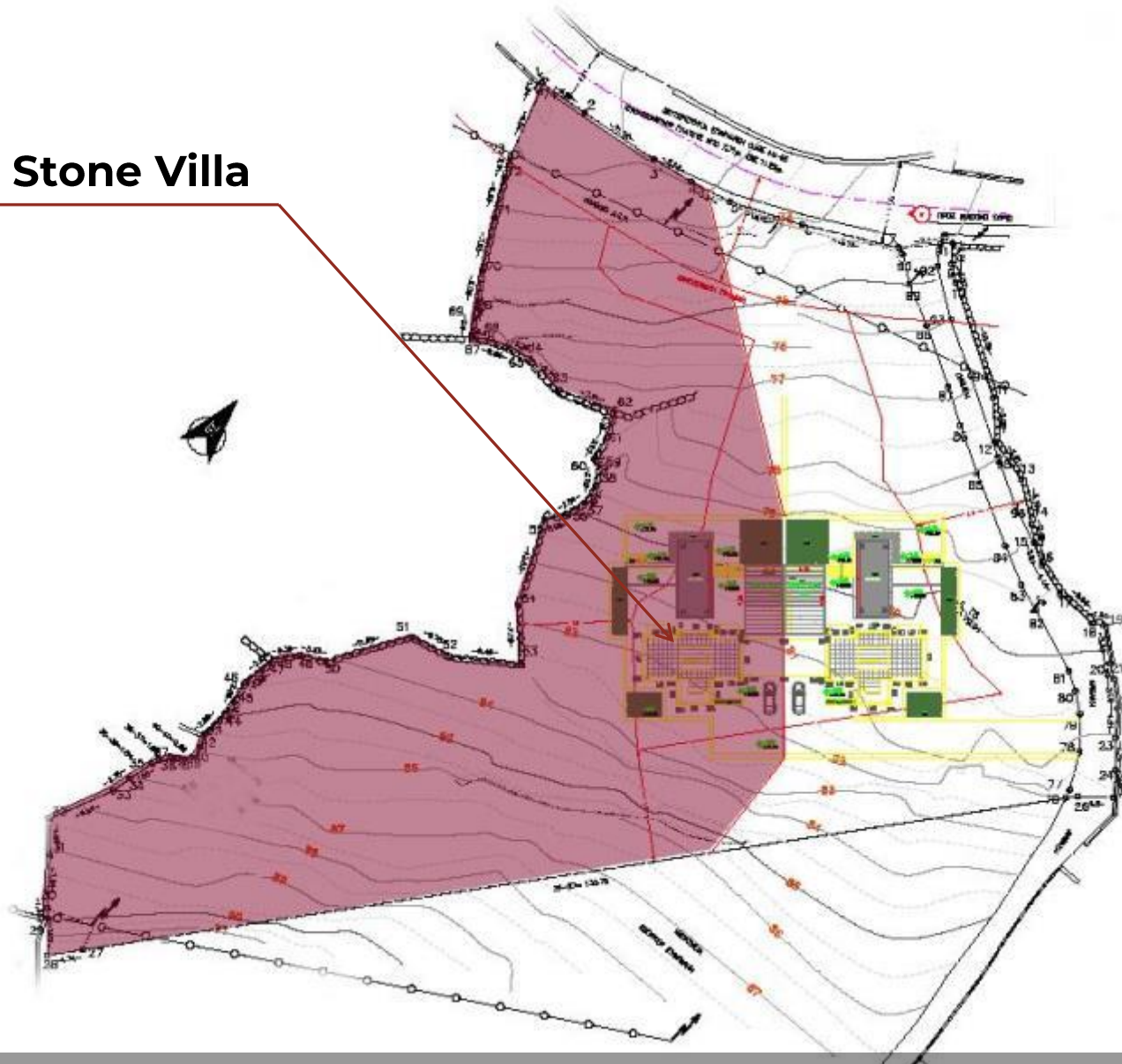

TOPOGRAPHIC PLAN WITH BOTH HOUSE

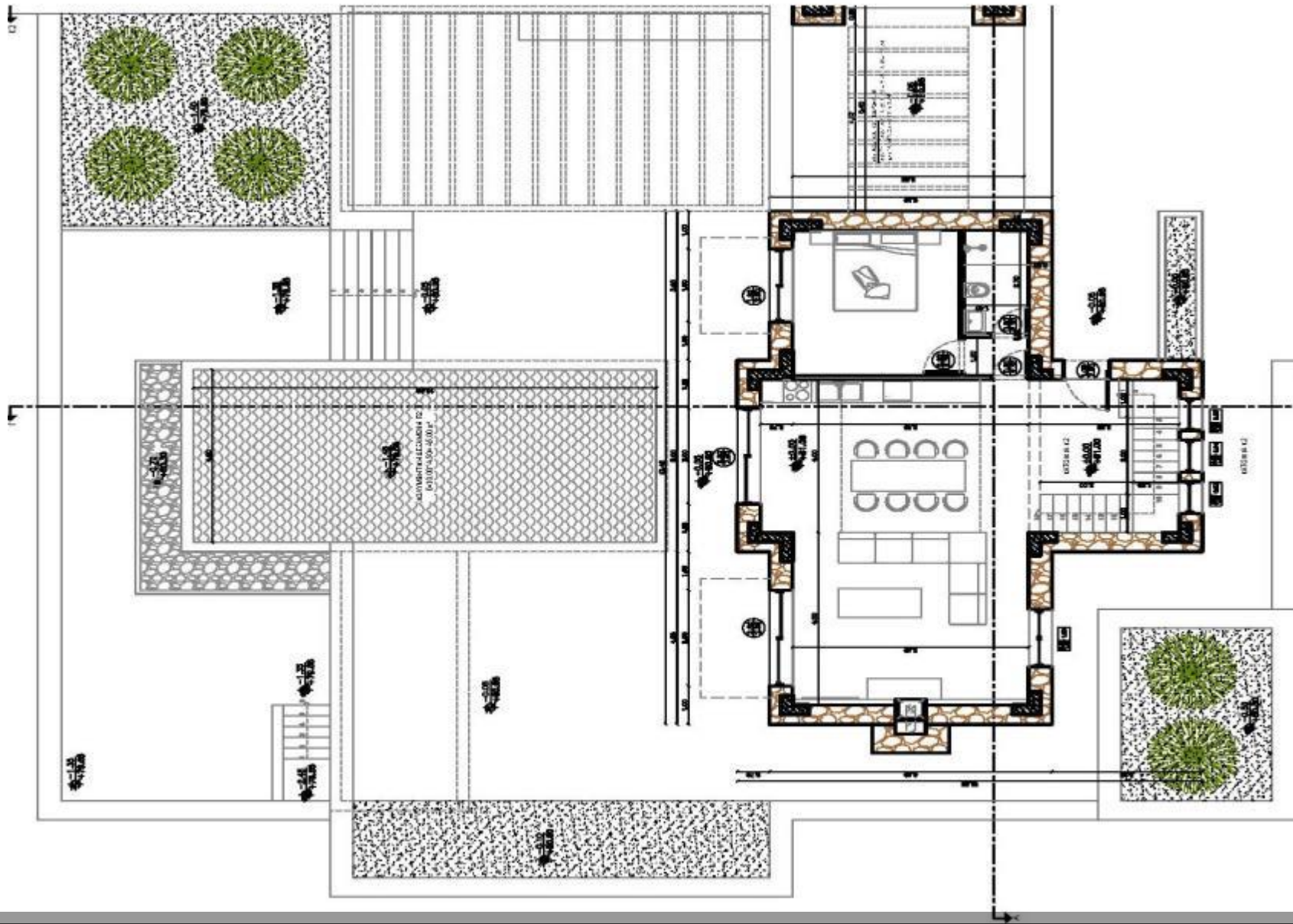

GROUND FLOOR

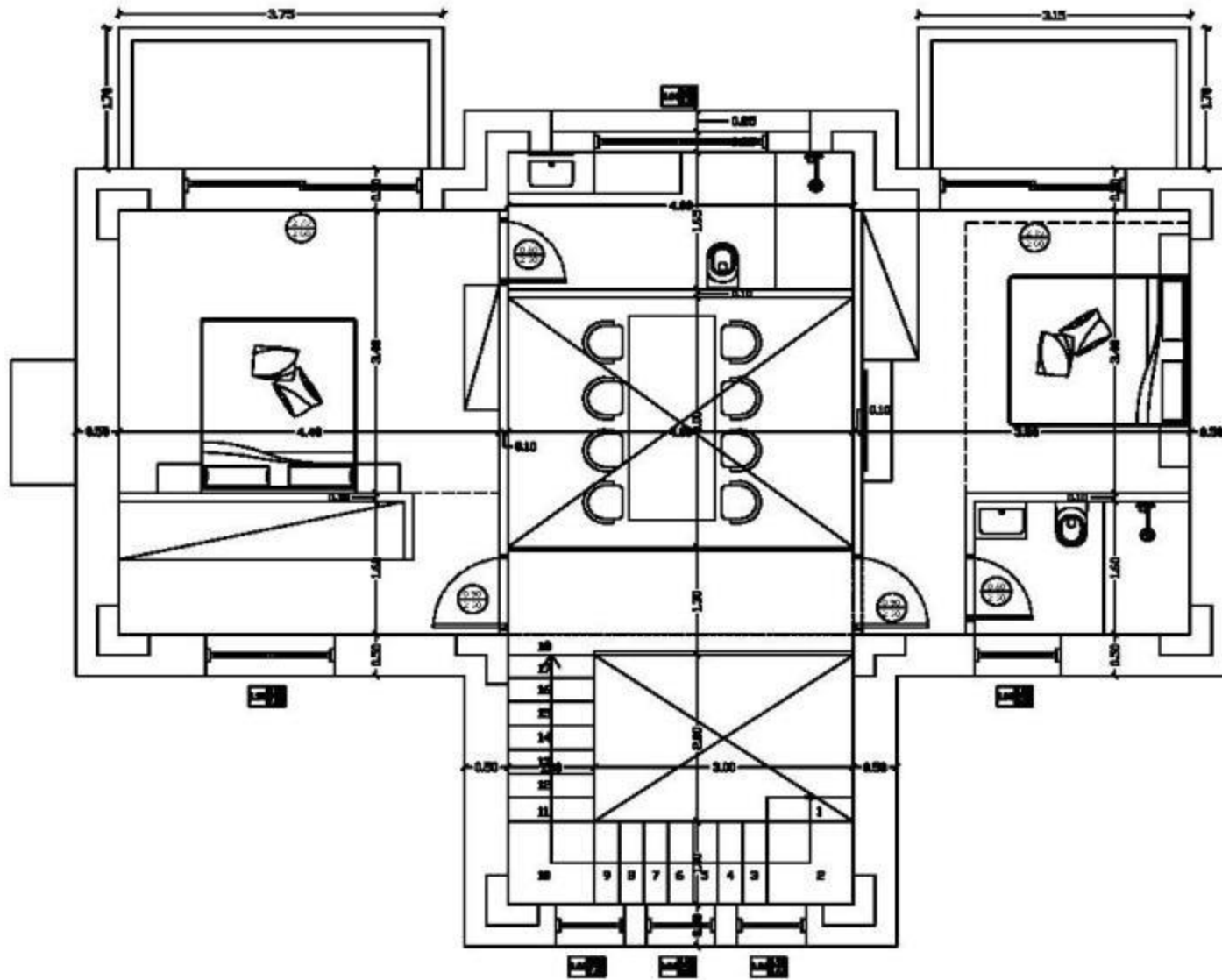

FIRST FLOOR



Details

Interior design of the villa

- Painted walls, non-slip tiled flooring, and high-quality tiled finish in bathrooms; plumbing, sinks and toilet bowls in place,
- Domestic appliances of well-known brands: refrigerator, cooker hood, kitchen range, oven, dish-washing machine, air-conditioners,
- Inox stair railing system,
- Each bedroom feature a fitted wardrobe,
- Aluminium window frames with double glazing,
- Insect screens, electric blinds,
- Satellite TV,
- Security alarm system,
- CCTV cameras, which can be checked remotely via an app

The exterior of the villa

- View of the sea and the mountains
- Swimming pool
- Outdoor and swimming pool lighting
- Gated entrance with remote control
- Landscape and shade gardening
- Barbecue area (pergola, oven, sink with running water)
- Water supply for technical works along the house perimeter
- Stone walls enclosing the property

Utilities

- Autonomous diesel heating system
- Solar batteries and electric water heater



- ❖ Total price with ready “key in hand” villa & pool & furniture & accessories!
- ❖ The property becomes full ownership!
- ❖ Easy purchase procedure (even without the participation of the buyer by special agreement)!
- ❖ Low and only tax on purchase!
- ❖ High degree of comfort: Mediterranean mild climate. More than 6 months of tourist season for renting a villa!
- ❖ Help in any matter and solving any issues!
- ❖ We give a guarantee for all our houses!